

PG Dial and Lever Governors

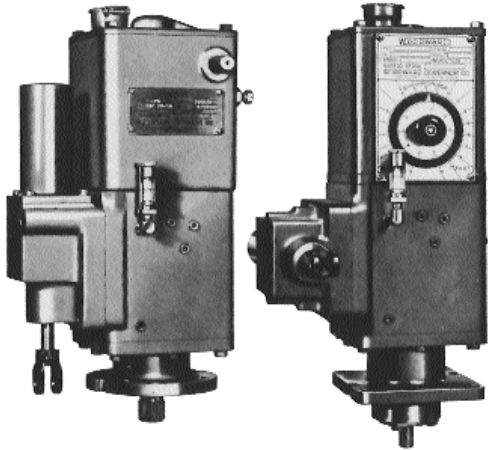

DESCRIPTION

Each PG governor contains the following elements:

- An oil pump, storage area for pressurized oil, and a relief valve to limit maximum oil pressure.
- A centrifugal flyweight head/pilot valve assembly to control oil flow to and from the governor power cylinder assembly.
- A power cylinder assembly (servomotor) to reposition the engine fuel rack. This can be either a spring-loaded or differential assembly.
- A compensating system to stabilize the governing system.
- Speed-setting adjustments.

APPLICATIONS

Woodward PG Dial and Lever governors control the speed of diesel, gas, and dual-fuel engines in a variety of fields. Their applications include engines driving pumps, compressors, alternators, variable speed dc generators, marine propulsion units, and paper machines.

Besides controlling speed, PG governors can also limit load and shut down the engine when the lubricating oil pressure fails.

Woodward customizes each PG governor to meet the needs of the engine and the application.

STANDARD FEATURES

- Lever or dial speed adjustment.
- Spring-driven, oil-damped ballhead to filter low frequency torsional vibrations at the governor drive.

OPTIONAL FEATURES

- Speed adjusting motor.
- Electric, oil, water, or pneumatic shutdown.
- Speed droop (as load increases, speed decreases).
- Wide speed range.
- Governor oil cooler or heater (for external mounting).
- Preloaded buffer springs for smoother control of two-cycle spark-ignition engines.
- Remotely mounted servomotor to simplify connection to fuel control.
- Servomotors with 16, 23, 33, 39, and 79 N·m (12, 17, 24, 29, and 58 lb-ft) (2/3 usable) are available in linear and rotary outputs.
- Overspeed test device to override governor speed setting. This permits testing of the engine overspeed trip by allowing the engine to run above rated speed.

- Lever or dial speed adjustment
- Spring-driven, oil-damped ballhead which filters frequency torsional vibrations
- Optional speed adjusting motor
- Electric, oil, water, or pneumatic shutdown
- Optional droop
- Wide speed range available

SPECIFICATIONS

Construction

Weight	Approximately 36 kg (80 lb)
Case and Pump Housing	Cast iron
Internal Parts	Aluminum, mild or case-hardened steel, and stainless steel
Dial Speed Setting Cover	Cast aluminum
Lever Speed Setting Cover	Sand cast aluminum

Mounting

Configuration	Vertical
Base	The round base and serrated shaft shown in dimension drawings are standard. Other bases, such as ones having UG-8 or UG-40 mounting dimensions and drive shaft, are available.
Drive Shaft	Either serrated or with keyway and key to carry a gear

Output

Fuel Control	Piston type with a 25 mm (1-inch) travel is standard. Two-thirds of the travel should be used between no load and full load with some overtravel at each end of the stroke; linkage should permit complete shutdown.
--------------	--

Control Characteristics

Speed Range	The common speed range is 150–1000 rpm with 800–1000 rpm being the recommended range for constant speed service. A wide speed range of 200–1600 rpm is available.
Operating Temperature	Continuous operating temperature is 60 to 93 °C (140 to 200 °F). [Contact Woodward Industrial Controls when working beyond these limits; the hydraulic fluid pour point must be below the lowest expected starting temperature.]
Work Capacity	16 N·m (12 lb-ft) is standard. A maximum of 11 N·m (8 lb-ft) may be used to move the fuel control linkage over the full range of governor travel.

Hydraulic System

Oil	SAE 10–50 oil depending on governor operating temperature
Self-contained Sump	Approximately 1.4 L (1.5 qt)
Viscosity	Should be 100–200 SUS under normal operating conditions



NOTE

Speeds in excess of 1000 rpm are available but require single-direction rotation. Oil coolers may also be required. Please consult Woodward Industrial Controls.

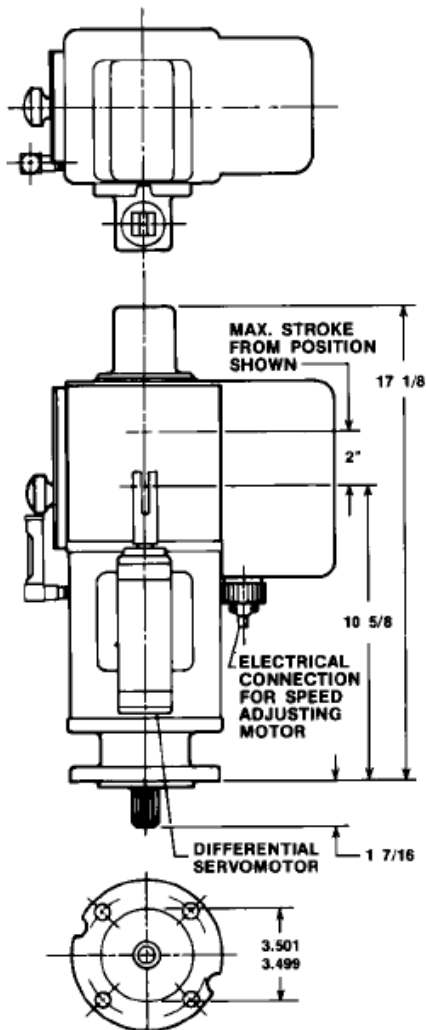

PG DIAL GOVERNOR WITH SPEED ADJUSTING MOTOR

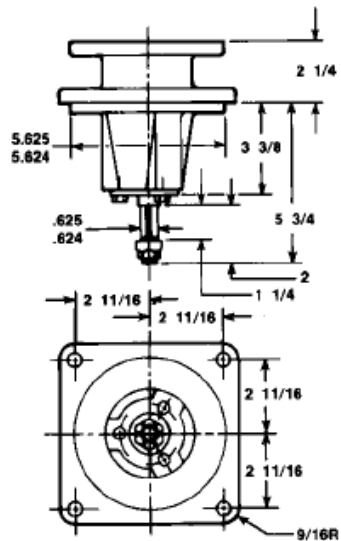

OPTIONAL BASE ASSEMBLY (KEY TYPE DRIVE)

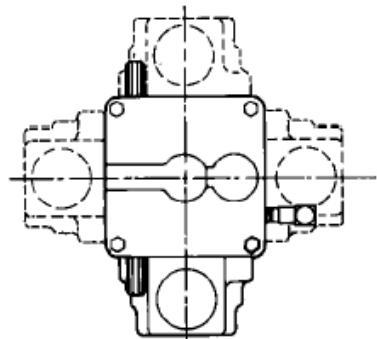

GOVERNOR CAN BE FURNISHED WITH SERVOMOTOR IN ANY OF FOUR PLANS AND QUADRANT POSITIONS AS SHOWN BY DOTTED OUTLINES.

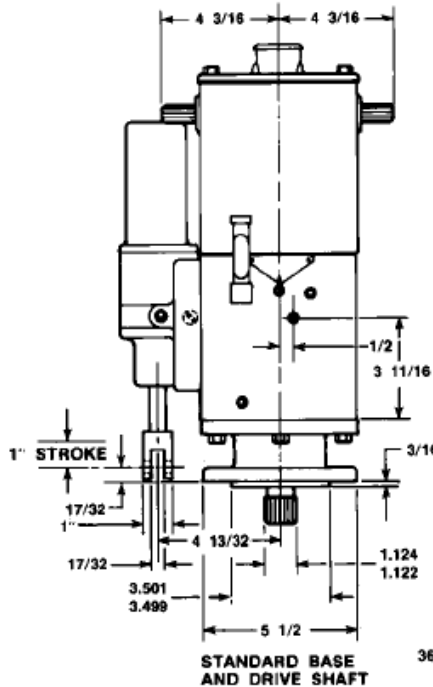
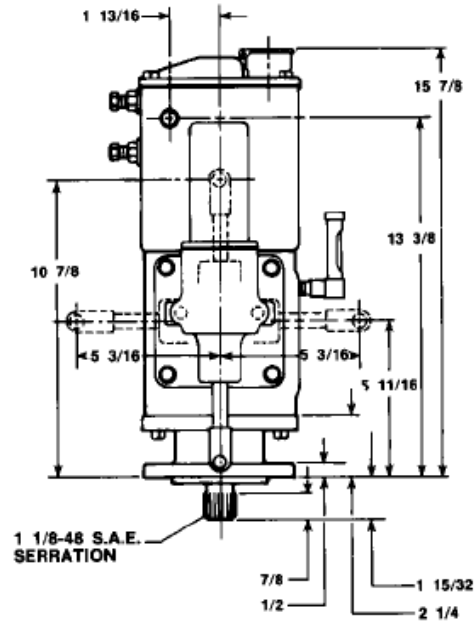

STANDARD BASE AND DRIVE SHAFT 36000-B-71



Woodward
Industrial Controls
PO Box 1519
Fort Collins CO, USA
80522-1519
1000 East Drake Road
Fort Collins CO 80525
Ph: +1 (970) 482-5811
Fax: +1 (970) 498-3058

Distributors & Service
Woodward has an international network of distributors and service facilities. For your nearest representative, call the Fort Collins plant or see the Worldwide Directory on our website.

Corporate Headquarters
Rockford IL, USA
Ph: +1 (815) 877-7441

www.woodward.com

This document is distributed for informational purposes only. It is not to be construed as creating or becoming part of any Woodward Governor Company contractual or warranty obligation unless expressly stated in a written sales contract.

© Woodward Governor Company, 1987
All Rights Reserved

01/12/F

For more information contact: