

Peak[®] 150

Digital Control for Steam Turbines

The Peak[®] 150 steam turbine control is a low-cost, compact, digital control for single-valve or single-valve rack steam turbines. It provides convenient operator control and speed display from the front panel. It is housed in a watertight, and dust-tight, enclosure. A corrosion-resistant enclosure designed to meet NEMA 4X requirements is also available.

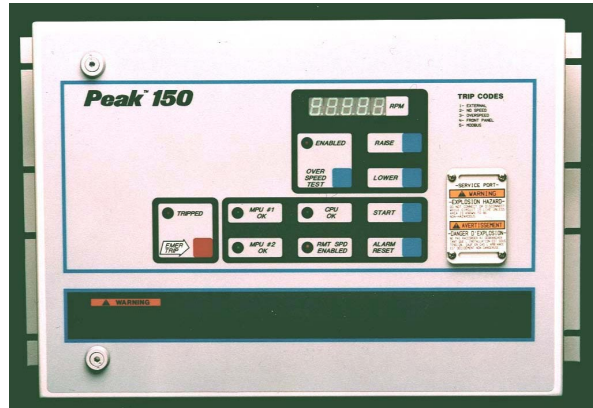

APPLICATIONS

The Peak 150 digital control is designed to control a steam turbine driving a mechanical load. It provides tight control of speed (NEMA D) and includes an input for a 4–20 mA remote speed control signal, which can be used for a process-generated input to control the speed setting. Other features include dual speed control dynamics and overspeed trip test capabilities.

OPERATION

The operation of the control is simple. To start the turbine, the steam-supply valve must be opened (manually or by other means). When the turbine comes up to the user-determined idle speed, the Peak 150 system takes control of the turbine—the steam-supply valve can then be opened fully. The Peak 150 control includes circuitry for detecting the loss of either MPU signal—this circuitry is automatically overridden for starting.

The turbine can be accelerated from idle speed to minimum governor speed either automatically (by using the remote Idle/Min Gov contacts or by using the front panel start), or manually (by using the front panel or remote Raise or Lower commands).

SETPOINT ADJUSTMENTS

Manual Mode

Turbine speed is adjusted solely by the front panel keys and the remote Raise and Lower discrete inputs. The Remote Speed setting analog input is ignored in this mode.

Remote Speed Set Mode

Turbine speed is determined by the Remote Speed Setting analog input. When the Remote Speed Setting Enable contact is closed and the turbine is at or above minimum governor speed, turbine speed will ramp from Min Gov Speed to the remote value at a user-defined rate. Once the speed setpoint output matches the setting of the Remote Speed Setting signal, the speed will change at a new user-defined rate for process control. If the Remote Speed Setting signal is disabled for any reason, the speed setpoint will remain at the last speed and the setpoint adjustment operates as it does in Manual Mode.

Combination Mode

This mode is similar to the Analog Remote Speed Set Mode, except that the speed demand generated by the discrete (front-panel and remote Raise and Lower contact inputs) and the analog Remote Speed Setting signal are compared for the highest value. This highest value is passed on as the commanded speed. If the Remote Speed Setting signal is disabled for any reason, control of the speed setpoint operates as it does in Manual Mode.

- Low-cost digital steam turbine control
- 16-bit, 12 MHz microprocessor
- Rugged NEMA 4 or NEMA-4X enclosure
- Front-mounted operator keypad and rpm/status indicators
- Easy setup and tuning using plug-in, hand-held terminal
- Modbus[®] communications capability
- Part of our Total Turbine Control System

PROGRAMMING UNIT

A small hand-held programmer (see illustration) connects to the Peak 150 to permit system configuration and tuning. System constants cannot be changed without this unit, so unauthorized changes are easily prevented by limiting access to the programmer.

CRITICAL SPEED AVOIDANCE

To protect the turbine and skid from excessive vibration, a critical speed band can be defined by the user. While within this band, turbine speed will change at a fast rate (user-defined) and cannot be stopped within the band.

COMMUNICATIONS

Serial communication using the Modbus[®] protocol is an option on the Peak 150. The transmission mode can be configured to be either RTU or ASCII mode. RS-232, RS-422, and RS-485 will all be supported through wiring to the proper terminals. Modbus, when purchased, permits communication with Programmable Logic Controllers or Distributive Control Systems. Speed, speed setpoint, alarm and shutdown conditions, and other pertinent control information will be reported on request from a master unit.

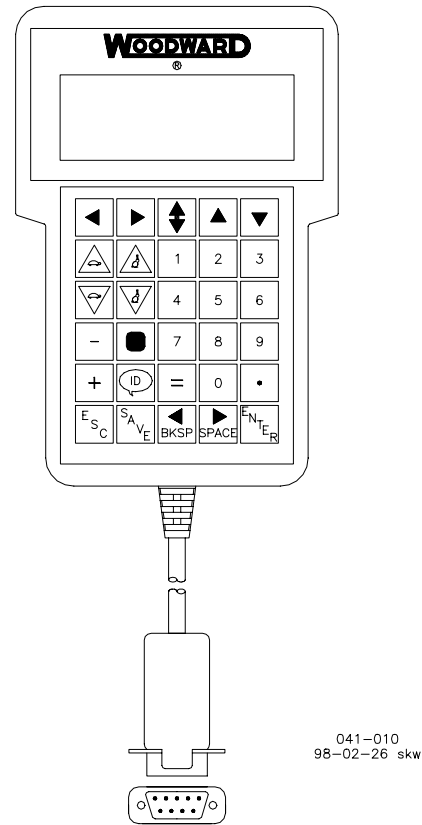

Hand Held Programmer

SPECIFICATIONS

Inputs

Magnetic Pickup Inputs (2)	Two identical inputs, high-signal-selected Minimum input voltage 1 Vrms, minimum frequency 200 Hz, maximum frequency 15 kHz
Analog Input (1)	Remote Speed Setting signal (4–20 mA or 1–5 Vdc, internal jumper selectable)
Discrete Inputs (8)	Remote (isolated, 5–28 Vdc)
Options	Raise speed Lower speed Emergency stop Alarm reset Remote speed set enable Start Idle/minimum governor Select high dynamics or overspeed test
Outputs	
Analog Outputs (2)	Actual speed output (scalable, 4–20/0–1 mA) Configurable readout (scalable, 4–20/0–1 mA)
Options	Actual speed Speed setpoint Actuator output Remote speed setpoint Valve ramp value
Actuator Output (1)	4–20 or 0–200 mA (internal jumper selectable)
Relay Outputs (4)	Internal jumpers provide choice of normally-open or normally-closed contacts

SPECIFICATIONS (continued)

Contact ratings are	2 A resistive @ 28 Vdc 0.3 A resistive @ 115 Vac Shutdown (de-energizes or energizes for shutdown) Alarm (de-energizes for alarm) Configurable Relay #1 Configurable Relay #2
Options	Alarm Trip output Shutdown Remote control Speed control MPU failure Overspeed trip Overspeed test Remote signal OK Speed switch #1 Speed switch #2 Hand valve #1 Hand valve #2

Operator Control Panel

Keypad Switches (6)

Options

Raise speed
Lower speed
Emergency trip
Start
Overspeed test
Alarm reset

LED Indicators (6)

Remote speed setting signal status
Shutdown status
MPU #1 status
MPU #2 status
CPU status
Overspeed test status

Digital Display

Five-digit LED speed display

Power

Input

Models are available with these input power requirements:
24 Vdc
90–150 Vdc or 88–132 Vac, 47–63 Hz
38 W

Maximum power consumption, all models:

Environmental Specifications

Operating Ambient Temperature

–25 to +65 °C (–13 to +149 °F)

Storage Ambient Temperature

–40 to +85 °C (–40 to +185 °F)

Humidity

Designed to meet US MIL-STD-810D, Method 507.2, Procedure II, induced, non-hazardous, cycle 5 (fifteen 24-hour cycles, varying 19–75% humidity, over 33–63 °C)

North American Regulatory Compliance

UL and cUL listed for Class 1, Division 2, Groups A, B, C, & D

Dimensions

Width

483 mm (19 inches)

Height

310 mm (12.2 inches)

Depth

105 mm (4.1 inches)

Woodward
 Industrial Controls
 PO Box 1519
 Fort Collins CO, USA
 80522-1519
 1000 East Drake Road
 Fort Collins CO 80525
 Ph: +1 (970) 482-5811
 Fax: +1 (970) 498-3058

Distributors & Service
 Woodward has an international network of distributors and service facilities. For your nearest representative, call the Fort Collins plant or see the Worldwide Directory on our website.

Corporate Headquarters
 Rockford IL, USA
 Ph: +1 (815) 877-7441

www.woodward.com

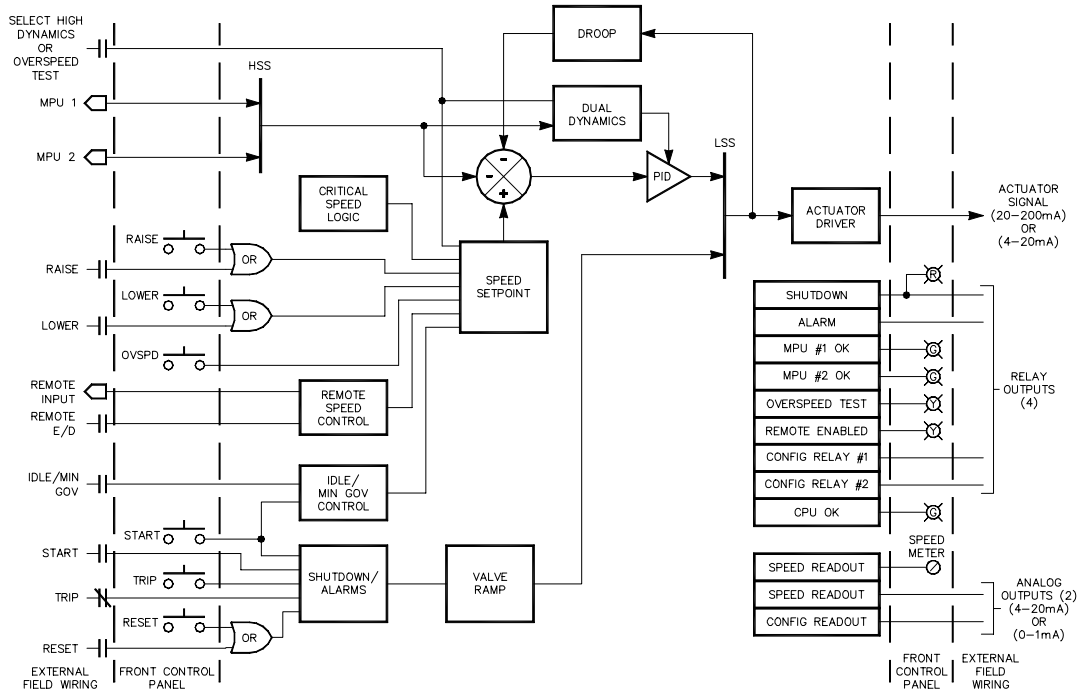

855-307
 93-08-27 DAR

Block Diagram

This document is distributed for informational purposes only. It is not to be construed as creating or becoming part of any Woodward Governor Company contractual or warranty obligation unless expressly stated in a written sales contract.

© Woodward Governor Company, 1990
 All Rights Reserved

For more information contact: