

TM-25LP TM-200LP Linear-Proportional Actuator

DESCRIPTION

The TM-25LP and TM-200LP actuators are electro-hydraulic, proportional actuators for positioning steam and fuel-control valves requiring low/high force linear inputs.

Factory setting determines if the actuator output shaft extends or retracts on increasing current.

APPLICATION

The TM-25/200LP actuators provide one inch (25 mm) of linear movement of valves for steam or gas turbines.

FEATURES

The actuators have aluminum cases and through-hardened stainless-steel internal parts.

A 40 µm low-capacity screen is provided in the supply inlet fitting to protect the torque motor servovalve in case of failure of the external filter.

The units will operate with either centrifugal or fixed-displacement type pumps providing hydraulic pressure.

The actuators are calibrated at the factory for bias in the minimum-fuel direction in event of the loss of input current.

A dual-coil torque motor is optional for redundancy. The dual-coil actuator has an optional position-feedback transducer.

For more information, refer to Manual 82450, TM-200LP and TM-25LP Actuator.

SPECIFICATIONS

Output Shaft

Hardened 17-4 stainless steel .625-inch (15.88 mm) round, with one-inch square (645 mm²) 17-4 stainless steel rod end attached by .375-inch (9.52 mm)/24-threads/inch threads. Optional rod end features .625-inch (15.88 mm) slot with .500-inch (12.70 mm) hole to pin linkage to valve. Other designs are available.

Work Capacity

TM-25LP	25 ft lbs (34 J) at 150 psig (1034 kPa)
TM-200LP	200 ft lbs (271 J) at 1200 psig (8274 kPa)

Output Force

TM-25LP	300 lbs (1334 N) maximum at 150 psig (1034 kPa) in either direction
TM-200LP	2400 lbs (10 675 N) maximum at 1200 psig (8274 kPa) in either direction

Response Time Constant (25% to 75% step)

TM-25LP	0.065 seconds at 250 psi (1724 kPa) 0.150 seconds at 100 psi (690 kPa)
TM-200LP	0.045 seconds at 1000 psi (6895 kPa)

Hysteresis

TM-200LP	±1 percent of travel
TM-25LP	±1 percent of travel

- Proportional Electro-Hydraulic
- One-Inch (25 mm) Linear Output
- Maximum Work Ratings from 25 to 200 ft-lbs (34 to 271 J)
- Corrosion Resistant Construction
- UL and CSA Listed Class 1, Div. 1 □ and 2 Groups □ C & D and □ Class 1, Div. 2, Groups B, C, D

Side Load

TM-25LP 50 lbs (222 N) maximum

TM-200LP 50 lbs (222 N) maximum

HYDRAULIC SUPPLY REQUIREMENTS**Fluid Types**

Mineral or synthetic based oils, diesel fuels, kerosenes, gasolines, or light distillate fuels.

Specific Gravity

0.6 to 1.0

Recommended Viscosity

6.0 to 400 centistokes

150-200 SSU

ISO 32 grade

External Filtration Required

10 µm nominal, 25 µm absolute

Hydraulic Cleanliness Level

ISO 4406 20/18/15 minimum

Woodward recommends adequate dither be used on all hydraulic actuators to minimize mA threshold and hysteresis which can result from second stage static friction or hydraulic contamination.

Dither is a low amplitude, relatively high frequency periodic signal that is superimposed on the servovalve input current signal. A typical dither signal generated by a Woodward control is:

25 Hz, 0–10 mA (tunable) amplitude

25% duty cycle, bipolar, square wave

Adequate dither is defined as that amount which produces no more than 0.0005 inch (0.013 mm) total oscillation in output shaft position.

Supply Pressure

TM-25LP 80–375 psig (552–2586 kPa)

TM-200LP 400–1200 psig (2758–8274 kPa)

Minimum Supply Flow (Steady State)

TM-25LP 0.5 gpm (1.9 L/min)

TM-200LP 0.5 gpm (1.9 L/min)

Maximum Supply Flow (Transient)

TM-25LP 5.0 gpm (18.9 L/min)

TM-200LP 5.0 gpm (18.9 L/min)

HYDRAULIC TEMPERATURE REQUIREMENTS**Ambient Temperature Range**

–40 to +250 °F (–40 to +121 °C)

Hydraulic Fluid Temperature Range

60 to 175 °F (16 to 79 °C)

ELECTRICAL CHARACTERISTICS

(For both TM-25LP and TM-200LP)

Input Current Range

20 to 200 mA

Null current shifts of up to ±4% of maximum rated current (200 mA) can occur due to variations in the following parameters: hydraulic supply and return pressures, hydraulic fluid temperature servovalve, and actuator wear.

Due to the inherent null shifts and position drift of all hydraulic servovalves and proportional actuators, engine control applications must be designed with these errors in mind.

Coil Resistance (at 70 °F/21 °C)

26 A (single-coil)

40 A (dual-coil)

Maximum Coil Current

250 mA

Position Feedback Transducer

Optional on dual-coil models only

CONNECTIONS

2-wire connection in .500-inch/14-TPI rigid conduit connector; two 18 gauge (~1 mm²) wires extend approximately 36 inches (914 mm)

.750-inch/16 TPI Hydraulic Supply connection
UNJF-3A (-08) (MS 33656)

.875-inch/14 TPI Hydraulic Drain connection
UNJF-3A (-10) (MS 33656)

MOUNTING

The attitude of installation does not affect the performance of the actuator.

Six-inch mounting flange with 2.938-inch (74.62 mm) hub contains six 0.438-inch (11.13 mm) bolt holes on 4.875-inch (123.82 mm) bolt circle; flange is approximately 0.625-inch (15.88 mm) thick.

WEIGHT

20 lbs (9 kg), approximate dry weight

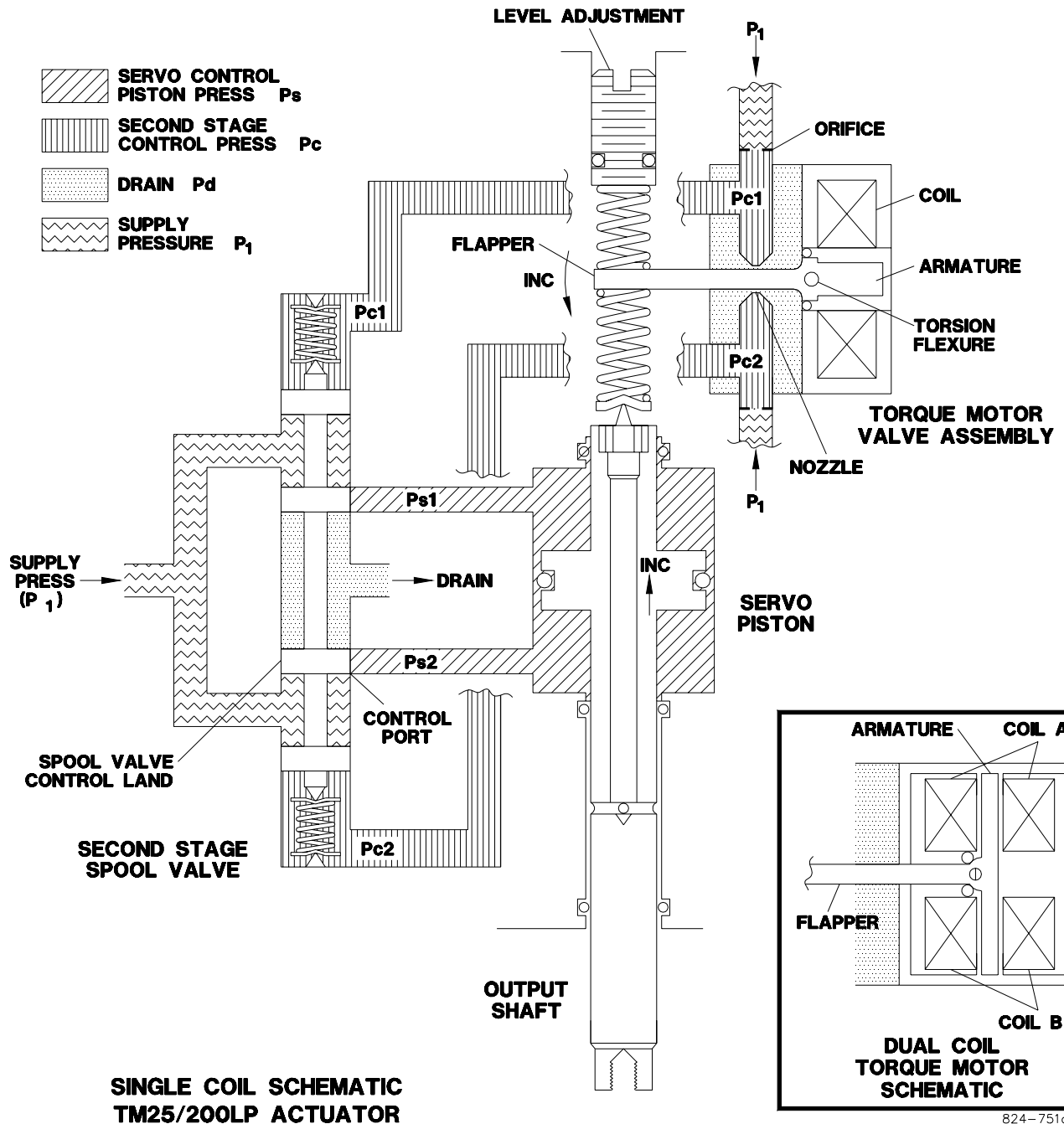

824-751g
99-06-30

SINGLE COIL SCHEMATIC TM-25/200LP ACTUATOR

A change in control signal to the torque motor results in a proportional change in terminal shaft position as follows: In the actuator, the torque motor servovalve is energized by the electronic control to generate a hydraulic pressure differential which is applied to the ends of the second stage spool valve. Hydraulic supply pressure to the servo piston is controlled by the second stage spool valve to move the double-acting piston and provide terminal shaft movement. Internal mechanical feedback recenters the torque motor flapper which equalizes pressure across the second stage spool valve and stops terminal shaft movement.

Woodward
 Industrial Controls
 PO Box 1519
 Fort Collins CO, USA
 80522-1519
 1000 East Drake Road
 Fort Collins CO 80525
 Ph: +1 (970) 482-5811
 Fax: +1 (970) 498-3058

Distributors & Service
 Woodward has an international network of distributors and service facilities. For your nearest representative, call the Fort Collins plant or see the Worldwide Directory on our website.

Corporate Headquarters
 Rockford IL, USA
 Ph: +1 (815) 877-7441

www.woodward.com

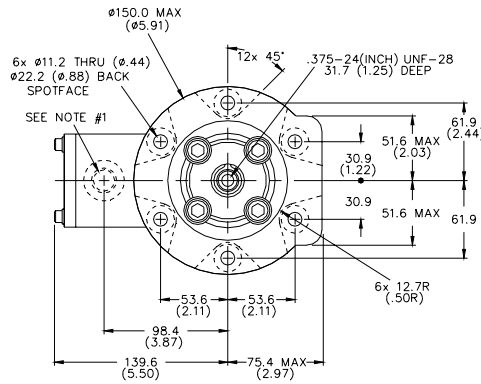
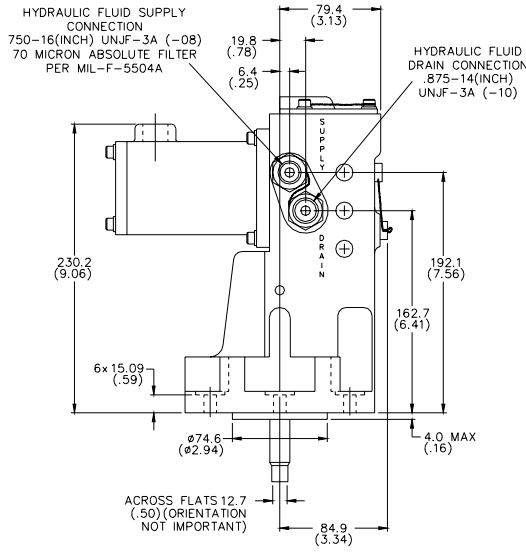

NOTES:

1. .500-14 (INCH) NPTF RIGID CONDUIT CONNECTION. ACTUATOR ELECTRIC INPUT SIGNAL, 18 GAUGE (A.W.G.) WIRE (2) EXTENDS APPROX 914.4 FROM OPENING.
2. 25.4 STROKE AVAILABLE. RECOMMENDED STROKE BETWEEN NO LOAD AND FULL LOAD IS 16.9.
3. PISTON EXTENDS TOWARD MAX POSITION WITH CURRENT INCREASE.
4. UL LISTED FOR USE IN CLASS 1, DIVISION 1, GROUPS C,D, AND CLASS 1, DIV 2, GROUPS B,C,D.
5. REFER TO WOODWARD SALES SPEC SHEET FOR WIRING INSTRUCTIONS.
6. INCHES SHOWN IN PARENTHESIS.

METRIC

824-040 C
 91-10-11 MCL

OUTLINE DRAWING OF SINGLE COIL TM-25/200LP ACTUATOR

This document is distributed for informational purposes only. It is not to be construed as creating or becoming part of any Woodward Governor Company contractual or warranty obligation unless expressly stated in a written sales contract.

© Woodward Governor Company, 1999
 All Rights Reserved

01/12/F

